

FRITZ ENGINEERING LABORATORY
LEHIGH UNIVERSITY
BETHLEHEM, PENNSYLVANIA

LEHIGH UNIVERSITY
Bethlehem, Pa.

Fritz Engineering Laboratory
Department of Civil Engineering

File: 205.4
August 4, 1958

Mr. W. Spraragen, Director
Welding Research Council
29 West 39th Street
New York 18, New York

ONR Status Report
No. 30
NR 064-345

Quarterly Report
(4/1/58 - 6/30/58)

Dear Mr. Spraragen:

Attached are our combined quarterly reports submitted by request of the
Welding Research Council.

Sincerely yours,

Lynn S. Beedle

LSB:mak

Enclosure

CC - Mr. T. R. Higgins
Mr. LaMotte Grover
Dr. G. H. Hickox
Mr. A. L. Tarr
Mr. H. B. Zackrison, Sr.

ASCE Committee on Plasticity Related to Design (EM)

Members, Lehigh Project Subcommittee, WRC

| | | |
|----------------------|----------------|----------------|
| Messrs: A. Amirikian | W. H. Jameson | H. Lawson |
| J. M. Crowley | B. G. Johnston | N. M. Newmark |
| F. H. Dill | J. Jones | R. M. Stuchell |
| S. Epstein | C. Kreidler | J. Vasta |

Bureau of Ships, Code 350

205.4
8/4/58

Lehigh University
WELDED CONTINUOUS FRAMES AND THEIR COMPONENTS
Quarterly Report April 1, 1958 to June 30, 1958

Plastic Design Commentary (205) (L. S. Beedle)

The first portion of the Commentary, reviewed earlier by the Lehigh Project Subcommittee was reviewed and discussed on May 7 at a meeting of the ASCE Committee on Plasticity Related to Design. The members of the committee agreed to prepare supplements to include desirable additions and these were received during the quarter.

Chapter Three, ANALYSIS AND DESIGN, was completed. The suggested changes to the first portion were incorporated in a new draft, identified as Part I and will be distributed to the members of the Lehigh Project Subcommittee and the Plasticity Committee of ASCE during the week of July 14. The two committees are being asked to approve the report at this time, although publication will await the conclusion of the draft of the next part.

With the exception of the chapter on Connections and the Article on Buckling, rough drafts have been completed on all remaining portions of the Commentary. It is planned to distribute this remaining material in two parts. Part II will contain Chapter Six, ADDITIONAL DESIGN CONSIDERATIONS, and will include articles that discuss shear force, local buckling, lateral buckling, axial force, column buckling and repeated loading. Part III will contain Chapter Seven, CONNECTIONS, and Chapter Eight, DEFLECTION.

George C. Lee has joined the project staff as a Research Assistant and will work on the Commentary, Connections and Lateral Bracing.

Design Procedures (205) (R. L. Ketter)

Progress Report No. 24, PLASTIC DESIGN OF PINNED-BASE GABLED FRAMES, is still being considered for publication in the ASCE Engineering Mechanics Division Journal.

Progress Report No. 28 by R. L. Ketter and B. T. Yen, PLASTIC DESIGN OF PINNED-BASE "LEAN-TO" FRAMES, will be ready for distribution to the committee in the near future. This paper extends the solutions given in Progress Report No. 24 to "lean-to" type rigid frames. Design methods are illustrated with a "lean-to" type mill building and a multi-span saw-tooth building. The paper shows the method of selecting relative member sizes corresponding to the least total weight of the structure.

Column Studies (205A) (T. V. Galambos and R. L. Ketter)

Progress Report No. 26, COLUMNS UNDER COMBINED BENDING AND THRUST, was approved by the committee, modified and sent to the ASCE for final approval and publication.

Work continued on preparing reports on lateral-torsional buckling of columns. A rough draft of a report on the basic theory of lateral-torsional buckling was completed. It is anticipated that these reports will be finished in the next quarter.

Exploratory work was done on the post-buckling strength of columns.

A proposal for twenty column tests was sent to the committee for approval. The primary reason for the tests is to determine post-buckling behavior under loading with four different combinations of end conditions. Fifteen of the tests are condition "d", three are condition "c" and one each of condition "a" and "b".

A copy of a Master's Thesis by D. Feder with a method of obtaining interaction curves of WF beam columns including residual stress directly from analytical expressions was received for the use of the project staff.

Dr. R. L. Ketter has terminated his employment at Lehigh University to take a position at the University of Buffalo as Head of the Civil Engineering Department.

Corner Connections (205C) (J. W. Fisher, G. C. Lee and G. C. Driscoll, Jr.)

Progress Report No. 23, BEHAVIOR OF WELDED CORNER CONNECTIONS, by J. W. Fisher, G. C. Driscoll, Jr., and F. W. Schutz, Jr. was published in the May Welding Journal, and was presented by J. W. Fisher at the April A.W.S. Meeting in St. Louis.

The six haunched corner connections described in the revised proposal of February 5, 1958, were tested and the results were in good agreement with the theory of Interim Report No. 39. The major points verified were:

1. Tapered haunched connections with an angle of 12 degrees between flanges will yield over the whole length of the haunch and the critical buckling length of the compression flange is 4.8 times the width of the flange.
2. The critical buckling length may be increased by increasing the angle between flanges, thus localizing the yielding at ultimate load.
3. The critical buckling length may be increased when the flanges are at critical angle by increasing the flange thicknesses properly.
4. The critical flange length, curvature, and thickness of curved knees were also verified, along with means of increasing critical flange length.
5. It was demonstrated that there is a definite need for positive lateral support of the compression flanges of haunched connections.

Progress reports on the analysis, design and tests of haunched connections will be prepared for committee review and possible publication.

John Fisher has completed his academic work and left Lehigh University to join the AASHO Road Test Project at Ottawa, Illinois.

Inelastic Instability -- Local Buckling (205E) (B. Thurlimann)

Progress Report No. 22, ON INELASTIC BUCKLING IN STEEL, by G. Haaijer and B. Thurlimann was published as an ASCE Proceedings Paper 1581 in the Journal of the Engineering Mechanics Division in April, 1958.

Inelastic Instability -- Lateral Buckling (205E) (T. Kusuda and B. Thurlimann)

Work was done on a report, BRACING OF BEAMS IN PLASTICALLY DESIGNED STEEL STRUCTURES, by B. Thurlimann, R. Sarubb and T. Kusuda. This report covers the results of beam tests conducted to verify the effect of moment gradient and spacing of lateral bracing on lateral buckling behavior.

Built-Up Members in Plastic Design (248) (T. Kusuda, A. Ostapenko and B. Thurlimann)

During the period, work was done on two reports. Tadao Kusuda's Dissertation, BUCKLING OF STIFFENED PANELS IN ELASTIC AND STRAIN-HARDENING RANGE, was completed. Progress Report No. 27, STRENGTH OF WIDE FLANGE BEAMS UNDER COMBINED INFLUENCE OF MOMENT, SHEAR, AND AXIAL FORCE, by T. Kusuda and B. Thurlimann was drafted.

Alexis Ostapenko joined the project work on the problem of ship bottom plating.

A proposal for an exploratory investigation of inelastic stability of longitudinally stiffened plates under lateral and axial loading (ship bottom plating) was submitted to the Department of the Navy and to the Bureau of Ships in April, 1958, and after some modifications it was approved in the meeting in Washington on June 2, 1958. Test specimens and loading conditions were analytically developed, and finally approved by the end of June, 1958.

The program will consist in axial testing of three identical specimens ($L/r = 54$, $b/t = 60$, $A_{stiff}/bt = 0.333$) subjected to lateral pressure equivalent to three levels of hydrostatic head: 0, 15 and 30 feet--one specimen for one pressure. Dimensions of the specimens and the test set-up are shown in Figs 1 and 2.

Design of the apparatus for the application of lateral pressure is being completed.

Rotation Capacity Requirements (268) (G. C. Driscoll, Jr.)

Committee approval was requested for submitting Progress Report No. 29, ROTATION CAPACITY REQUIREMENTS FOR CONTINUOUS BEAMS, to the ASCE for publication.

A report on the rotation capacity requirements for single-span frames has been completed and will be distributed for committee review.

Multi-Story Frames (273) (Le-Wu Lu and G. C. Driscoll, Jr.)

A literature survey on the plastic analysis, design and stability of multi-span frames has been completed. This report will be reproduced and distributed to the committee. Some preliminary problems in multi-story frames are being studied to aid in preparation of a proposal for this program.

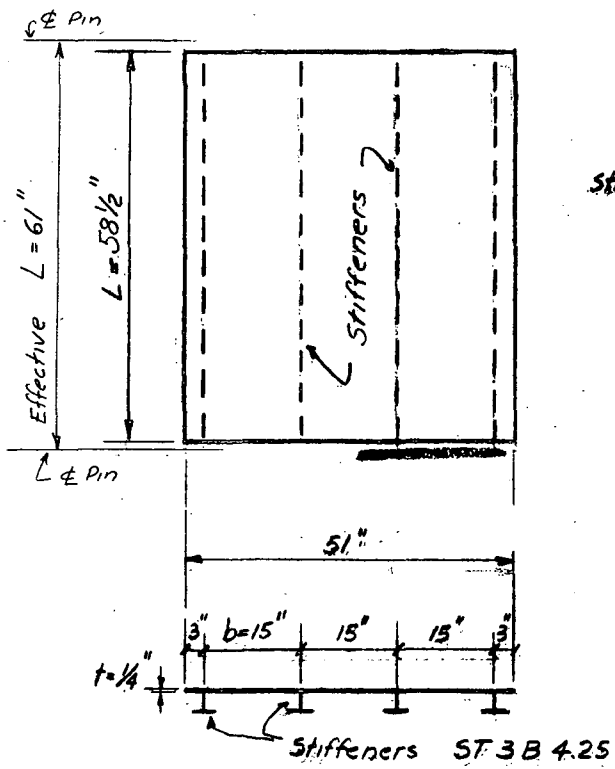

$L/r = 54$ $b/t = 60$
 $A_{stiffener}/A_t = 0.333$

Fig. 1. SPECIMEN DATA

Scale: $1'' = 30''$

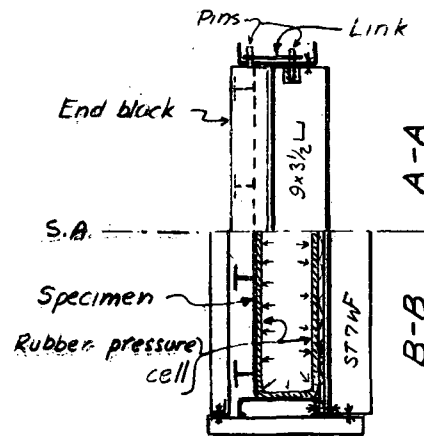
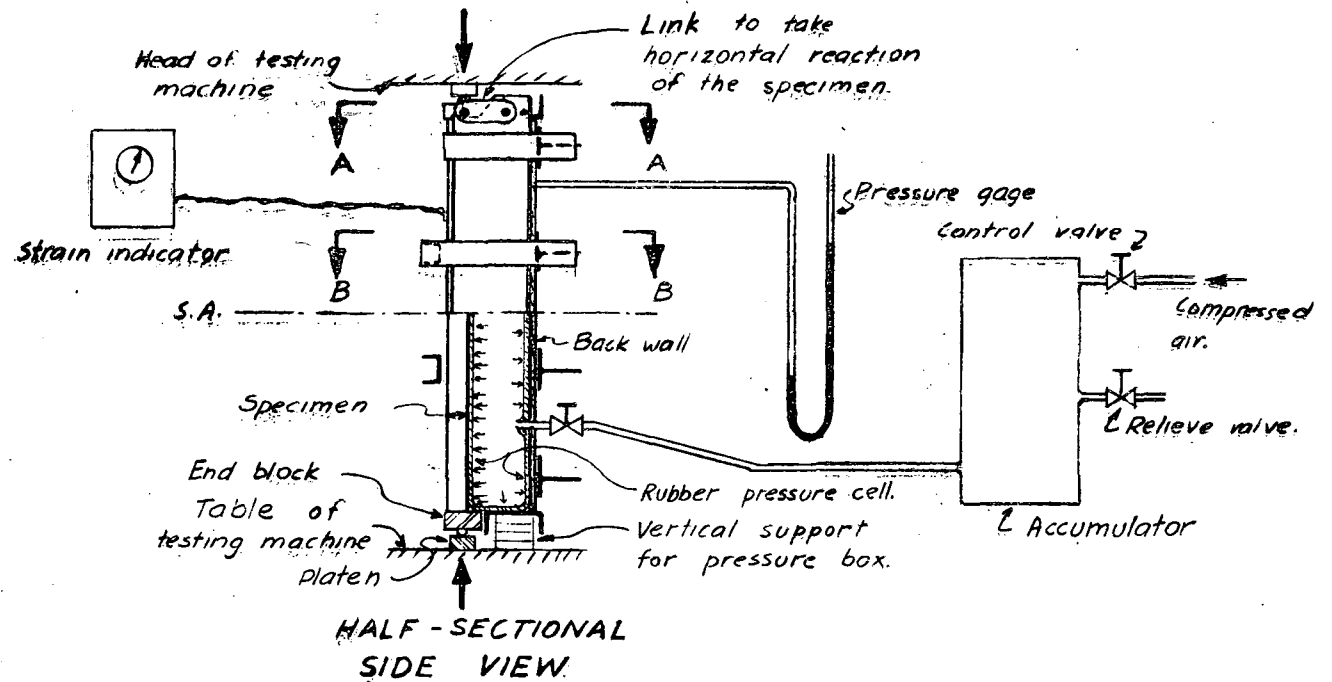

SECTIONS A-A and B-B

Fig. 2. TEST SET-UP and DETAILS of PRESSURE BOX.

Scale: $1'' = 30''$

205.4
INDEXED

396
No list

205.4

LEHIGH UNIVERSITY
BETHLEHEM, PENNSYLVANIA

DEPARTMENT OF CIVIL ENGINEERING
FRITZ ENGINEERING LABORATORY

205.4

July 14, 1961

ONR Status Report
No. 38
NR 064-345

Mr. K. Koopman, Director
Welding Research Council
29 West 39th Street
New York 18, New York

Semi-Annual Report
(10/1/60-6/30/61)

Dear Mr. Koopman:

Attached are our combined semi-annual reports submitted by request of the WELDING RESEARCH COUNCIL. Because of the delay in preparing this report, three-quarters of the year are included rather than the usual period.

Sincerely yours,

Lynn S. Beedle

GCD:lm

Encl.

cc: Messrs. T. R. Higgins
LaMotte Grover
G. H. Hickox
A. L. Tarr
H. B. Zackrison, Sr.

ASCE Committee on Plasticity Related to Design (EM)
Members, Lehigh Project Subcommittee, WRC

| | | |
|-----------------------|----------------|----------------|
| Messrs: T. R. Higgins | G. Fox | C. Kreidler |
| A. Amirikian | L. Grover | N. M. Newmark |
| L. S. Beedle | W. H. Jameson | E. Pisetzner |
| J. M. Crowley | B. G. Johnston | R. M. Stuchell |
| F. H. Dill | T. C. Kavanagh | J. Vasta |
| S. Epstein | R. L. Ketter | |

FRITZ ENGINEERING LABORATORY
LEHIGH UNIVERSITY
BETHLEHEM, PENNSYLVANIA

Lehigh University
WELDED CONTINUOUS FRAMES AND THEIR COMPONENTS

(Reports for the period October 1, 1960 to June 30, 1961)

Reports on selected topics were presented at the Subcommittee Meeting on January 16, 1961. These reports were presented in the Minutes of that meeting in "REPORTS OF PROGRESS", Welding Research Council, XVI(4), April 1961, p. 29-34. Reports for the same period on topics which were not covered at that meeting are included in the following report as well as later reports on all topics.

PLASTIC DESIGN COMMENTARY (205)

The seven Progress Reports in the series "Commentary on Plastic Design in Steel" were revised and edited for publication as a single final report. This report was published in June 1961 as ASCE Manual No. 41, copyrighted by ASCE and AWS. Closures to four discussions of the commentary are being written.

MEETINGS

Members of the project staff were active in national and regional meetings of several engineering groups at which a number of papers were presented. Among these meetings were the October annual meeting of the ASCE in Boston, the April annual meeting of the CRC in Washington, D.C., the April annual meeting of the AWS in New York, and five engineering conferences of the AISC. Executive Committee meetings of the CRC and WRC were also attended by project staff members. Talks on plastic design were given at local section meetings of the Engineers Society of Western Pennsylvania and the Central Pennsylvania Section of ASCE.

COLUMNS IN CONTINUOUS FRAMES (205A) R. C. Van Kuren, T. V. Galambos

1. A report entitled "BEAM-COLUMN EXPERIMENTS" (205A.30) by R. C. Van Kuren and T. V. Galambos was completed and will be distributed to the Committee by about July 10. This report summarizes the beam-column experiments performed on 42 as rolled 8WF31, 4WF13, 8B13 and 8WF40 columns in the past 12 years. The paper contains the outline of the test programs, the description of the experimental setups, the discussion of the test results,

and comparisons with "exact" and empirical interaction curves.

The principal conclusions reached from the experiments are:

- (1) Moment carrying capacity and rotation capacity is increased as the axial force and the slenderness ratio decrease.
- (2) The principal cause of failure for unbraced beam-columns bent about the strong axis is lateral-torsional buckling. For unbraced shorter columns ($L/r < 50$) and for all braced columns failure took place by excessive bending in the plane of the applied moments. Local buckling usually occurred after unloading.
- (3) It was found that the most critical loading case is that condition when two equal moments cause single curvative deformation. The least critical loading was that which caused double curvative deformation.
- (4) The variation of cross-sectional shape seemed to have little effect on column strength when failure was by excessive bending in the plane of the applied moments.
- (5) The correlation between theoretical loads based on an assumed failure by excessive bending in the plane of the applied moments and test results for all experiments which failed in this manner was found to be excellent.
- (6) The correlation between the experimental results for the tests which failed by lateral-torsional buckling was good.
- (7) A comparison between the experimental results and the Column Research Council Interaction Formula (which takes into account secondary effects, moment gradient, and lateral-torsional buckling) provides experimental proof for the applicability of this formula in design.

LATERAL BRACING REQUIREMENTS (205H)

T. V. Galambos, G. C. Lee, and A. Ferrara

1. A report entitled "THE POST-BUCKLING STRENGTH OF WIDE-FLANGE BEAMS" by G. C. Lee and T. V. Galambos (205E.12) was completed and distributed to the Committee. This report

described as experimental program aimed at determining the critical spacing of lateral bracing in plastically designed beams. Five experiments on 10WF25 having varying unsupported lengths have shown that

- (1) If $L/r_y \leq 45$, failure is triggered by local buckling, even if lateral buckling is present. These beams showed sufficient post-buckling rotation capacity for use of the beams in plastic design. Thus it was concluded that the present rule for spacing ($L = 35 r_y$) under uniform moment can be liberalized.
- (2) For the experiment with $L/r_y = 50$, the beam showed no postbuckling reserve, and failure was initiated by lateral buckling as soon as the fully plastic moment was reached.
- (3) Experimental work was continued on beam-purlin assemblies to study the effectiveness of
 - a) Various lengths and sizes of continuous purlins welded to the main beam.
 - b) Various beam-purlin connections.

The list of the completed experiments is shown in Table I. In this table the LB Series tests designate tests in the basic study to determine what purlin stiffnesses are required. The P-Series tests are experiments designed to study the effectiveness of other than welded continuous purlins. Further tests are planned in the latter phase of the research to determine the influence of varying the beam sizes and the adjacent lengths.

Currently a report on the LB Series tests is under preparation. Besides describing the experiments, the data obtained will be carefully studied and conclusions will be drawn with regard to the bracing requirements in plastic design. This work is not yet complete, and therefore no conclusions are given here.

STIFFENED PLATES (248) T. Lee and A. Ostapenko, R. H. Rampetsreiter

Residual stress intensities and distributions were measured in two longitudinally stiffened plate panel specimens, T-8 and T-9. It was found that residual stresses due to welding have a marked influence on the strength of longitudinally stiffened panels. A compression test on a short longitudinally stiffened panel was conducted (T-10S, $L/r = 20$).

Determination of the properties of the specimen material in compression is in progress. A special test jig had to be developed for this purpose. Results of this work will be a basis for an M.S. thesis.

A report on all experimental work conducted from May 1960 to February 1961 is being prepared.

A theoretical study on the elasto-plastic analysis of simply supported plates subjected to axial and lateral loading is in progress. This study involves extensive use of a digital computer and will lead to a PhD dissertation.

A draft of "Scantlings of Longitudinally Stiffened Ship Bottom Plating - tentative ideas on Design Method" was submitted to the Bureau of Ships. This paper gave an outline for developing a proposed practical procedure for design of longitudinally stiffened ship bottom plating. It also served to point out gaps in the knowledge which have to be filled by further research before a rational design procedure can be evolved.

A paper "Apparatus for Testing Plate Panels Under Axial and Lateral Loading" by A. Ostapenko was prepared and submitted for publication in "Experimental Mechanics", the journal of SESA.

MULTI-STORY FRAMES (273)

V. Levi, W. Hansell, and G. C. Driscoll, Jr.

Studies for which a report is almost completed show that plastic design of braced multi-story frames can result in savings in the weight of structural members used. The studies have shown the need for methods of designing bracing and calculating deflections. They have also shown the necessity for finding practical methods of incorporating results of research on column stability, restrained columns, and frame stability into the design. Some of the ideas which are awaiting only time to explore, develop and report are:

- (1) Some unbraced frames designed for vertical load only with a load factor of 1.85 may have adequate strength to resist combined wind and vertical loads factored by 1.40 without additional bracing. Knowledge of the loading and geometry within which this is true would be very valuable.

- (2) When small amounts of diagonal bracing are used in a frame they have a high efficiency in preventing sidesway due to either lateral load or frame instability.
- (3) When the participation of diagonal bracing is considered in the overall behavior of a frame subjected to lateral load, the mechanism derived may prove to be different than that which would form without bracing. This may show that sway type mechanisms will not tend to form in braced frames until extreme heights or extreme lateral loads are reached.

A process of examining extremes of the states of possible equilibrium of beams and columns in a frame having a known amount of vertical load may lead to valuable approximate solutions of several of the unsolved problems.

- (1) Limits of the resistance to lateral load of a given unbraced frame may be obtained.
- (2) Limits of the resistance of the same frame with bracing may be determined.
- (3) Moment distributions causing the greatest and least possible column sway under a given load may be studied and lead to reasonable estimates of the sway of either braced or unbraced frames.

The method may also prove to be valuable for estimating moment distributions and deflections in the elastic range. This will be attempted for an existing building.

FRAME STABILITY (276)

L. W. Lu, Y. C. Yen, and G. C. Driscoll, Jr.

Three model frames were tested to verify the inelastic buckling solution developed last year. Figure I shows the test results from three pairs of model frames loaded by dead loads. These frames were made from M2362 sections (a special 2-5/8 in x 1-7/8 I-shape) and had column slenderness ratios of 40, 60, and 80. The graph shows test load divided by simple plastic theory ultimate load plotted against column slenderness ratio. The ultimate loads for the three specimens all exceeded the theoretical load for initial sidesway motion and are quite close to the predicted frame strength. Detailed analyses of the test results are now under way preparatory to making a complete report.

A method was developed for determining the support reactions and the deformations of portal frames in the elastic-plastic range including the effects of initial residual stresses and column instability. The method can also be used to determine the load-carrying capacity of braced frames and the buckling strength of unbraced frames. A paper "Analysis of Frames Loaded into the Plastic Range" (276.6) by M. Ojalvo and L. W. Lu covers this method. The paper has been submitted to ASCE for publication.

A numerical-iterative procedure for solving various instability problems, particularly suitable for a digital computer program has recently been developed. It is believed that this procedure will lead to an easier solution of the problem of inelastic instability of frames carrying combined vertical and horizontal loads.

RESTRAINED COLUMNS (278) T. V. Galambos and Y. Fukumoto

1. A paper entitled "NOMOGRAPHS FOR THE SOLUTION OF BEAM-COLUMN PROBLEMS" (278.5) by M. Ojalvo and Y. Fukumoto is completed and will be distributed to the Committee in July 1961. This paper contains essentially these portions of M. Ojalvo's dissertation which were not published in the paper "RESTRAINED COLUMNS" by M. Ojalvo (ASCE Proceedings, Vol. 86, EM5, October 1960). This latter paper was mainly concerned with theoretical implications involved in the solution of restrained columns problems, whereas the paper by M. Ojalvo and Y. Fukumoto contains nomographs and charts useful for solving various practical problems. The information presented in this report is useful in that it can be directly used for designing columns in multi-story frames and in the solution of problems in inelastic frame instability. The use of the charts is illustrated by several illustrative problems which are worked out in detail.

2. Work was continued on the design of columns in multi-story frames. A report (by M. Ojalvo, V. Levi) will be forthcoming in July or August 1961 summarizing this work.

DESIGN OF BEAM-COLUMNS (287) T. V. Galambos and Y. Fukumoto

Work was started in reducing research data into design recommendations for beam-columns of WF shape. The work will also include extension of currently available methods to include beam-columns of other shapes (box) and high-strength steels.

LIST OF EXPERIMENTS FOR LATERAL BRACING REQUIREMENTS

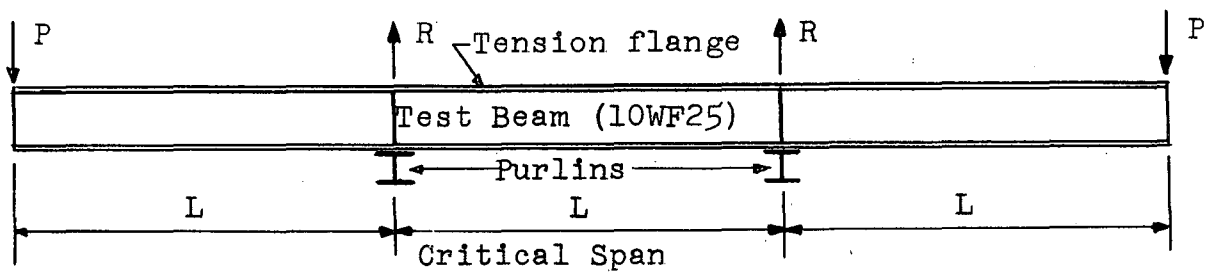

| Test No. | L_{cr} (in) | Purlin Length (in) | Purlin Section | Test** Results | Purpose of Experiment | Remarks |
|----------|------------------|--------------------------|-------------------|-------------------|--|--|
| LB-12 | 40 _{ry} | 84* | 4I7.7 | O.K. | To study per- formance of | Loading through tension flange |
| L-13 | 40 _{ry} | 84* | 3I5.7 | O.K. | various size and length | |
| LB-14 | 40 _{ry} | 84* | M2362 | N.G. | purlins as lateral brac- ing | |
| LB-18 | 40 _{ry} | 84* | 3I.5.7 | O.K. | | Loading through compression flange |
| LB-19 | 40 _{ry} | 148* | 3I5.7 | N.G. | | |
| LB-20 | 40 _{ry} | 116* | 3I5.7 | O.K. | | |
| LB-21 | 40 _{ry} | 84 ⁺ | 3I5.7 | N.G. | To study per- formance of | |
| LB-22 | 40 _{ry} | 56 ⁺ | 3I5.7 | O.K. | various length purlins on one side only | |
| P-1 | 20 _{ry} | - | - | O.K. | To obtain basic M-Ø | 10WF25 Section |
| P-2 | 20 _{ry} | - | - | O.K. | curves without instability (control tests) | 3B13 Section |
| P-6 | 40 _{ry} | 84* | 3I5.7 | | To study various types | Welded discon- tinuous purlins |
| P-7 | 40 _{ry} | 84* | 3I5.7 | | of purlin attachment | Bolted continuous purlins |

* On both sides of test beam

** OK or NG refer to ability of beam-purlin assembly to deliver plastic hinge.

+ Purlins one side only

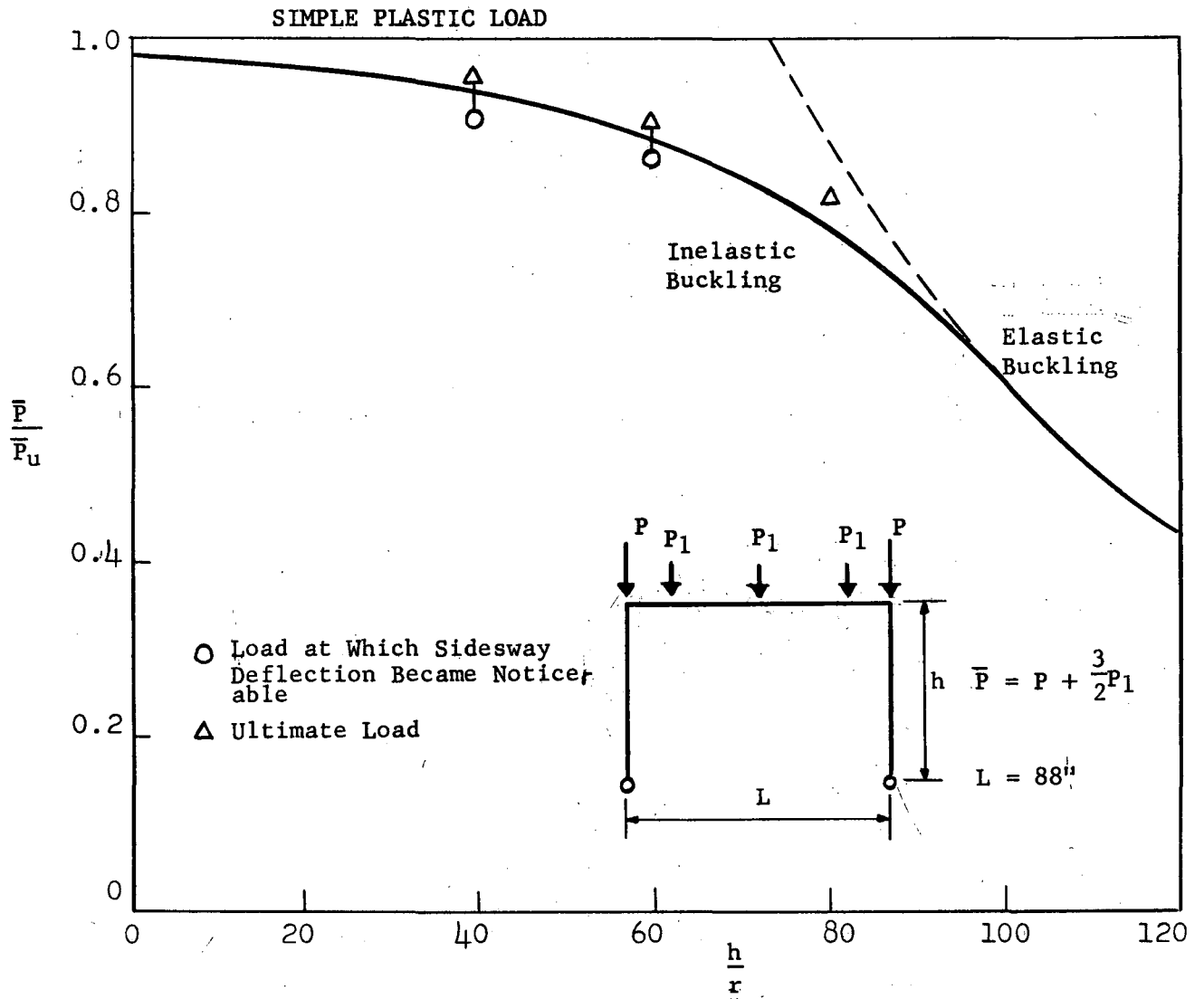

Figure 1

Load Versus Slenderness Ratio Curve for Model Frames